

TKL201S Technical Specification

Ver.1.1

Takion Co.,Ltd
WEB: www.takion.jp MAIL: info@takion.jp

All specifications may be changed without notice.

1. Description

The TKL201S is a switching regulator IC focused on LED driving. It operates with AC supply pulsating current after rectification without smoothing in electrolytic capacitor less method for LED drive. It monitors the load current and realizes constant current drive by adjusting the pulse duty.

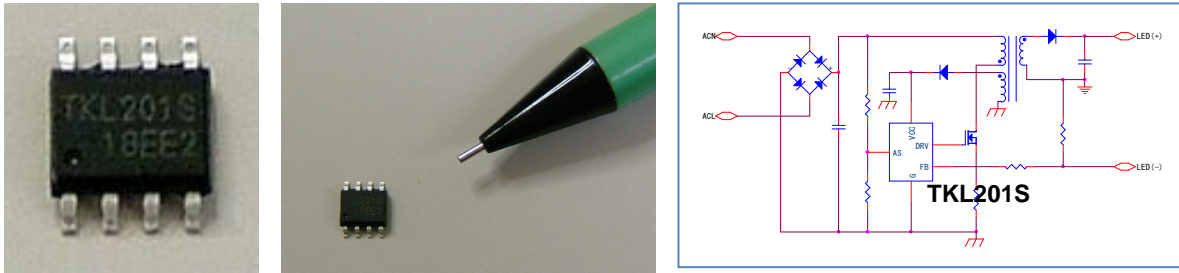

Standard isolated driver circuit with minimum parts count

2. Features

- The TKL201S realizes lower cost and miniaturization of driver circuit with minimum parts count.
- It constitutes isolated and non-isolated fly-back converter.
- It operates with AC supply pulsating current without smoothing by electrolytic capacitor, and also can operate with DC.
- It drives the load with constant current by PWM switching of 67kHz on average to external MOSFET.
- It is capable of worldwide power supply voltage (from 85 to 265V)
- It includes a input voltage monitoring function, which is also simple PFC.
- Over current protection, Over voltage protection, Thermal shut down. If they operate, TKL201S stops switching on latching mode.

Applications

- LED light bulb, LED straight bulb, other LED lighting system
- AC adapter
- Battery charger

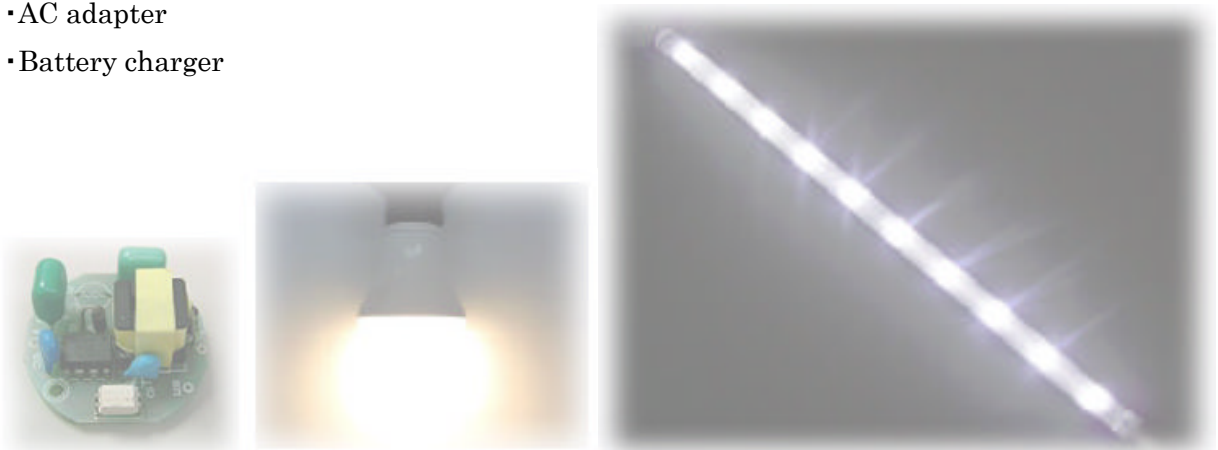

3. Block Diagram

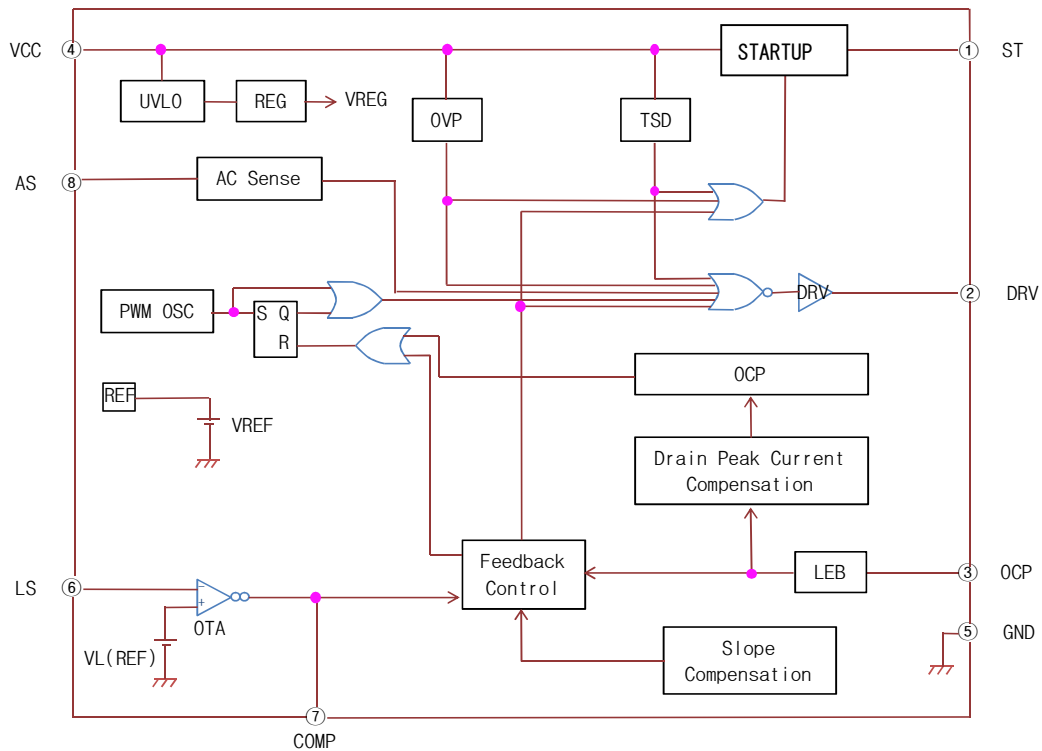

4. Pin Functional Description

Pin #	Symbol	Function
1	ST	Start-up current input
2	DRV	Gate drive output
3	OCP	Current limit sense input
4	Vcc	Power supply input
5	GND	Ground
6	LS	LED (Load) current sense input
7	COMP	Error-amp output / Phase compensation
8	AS	AC Sense (Input voltage monitor)

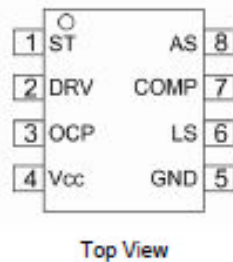

5. Package Outline

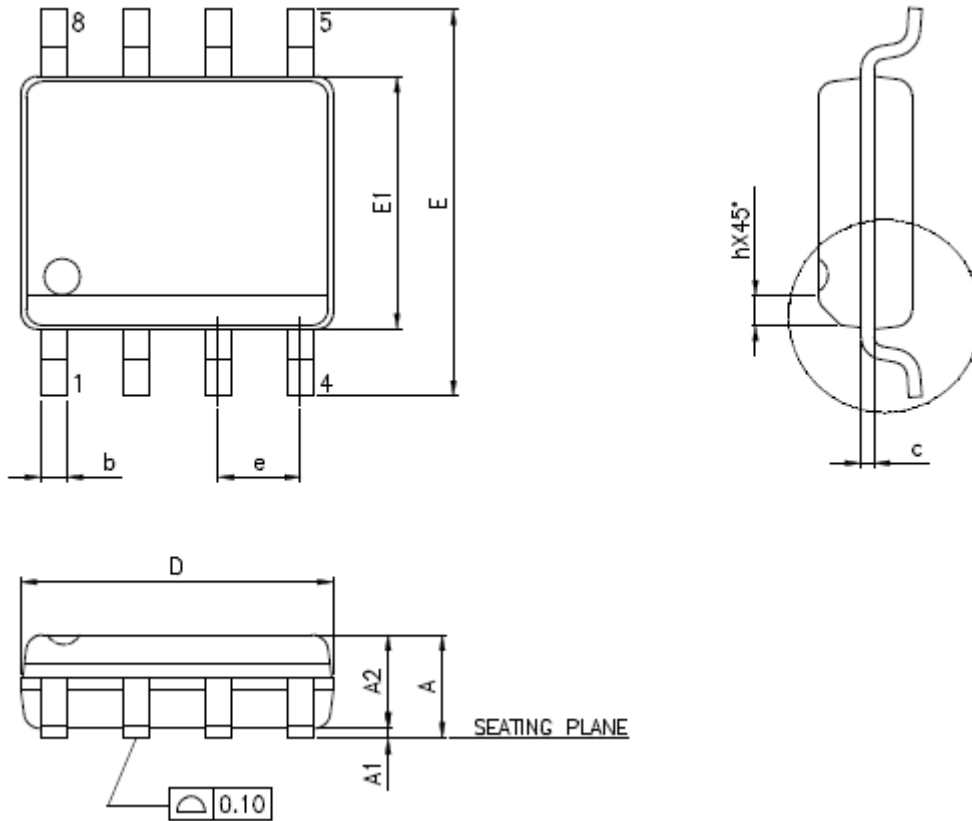

SYMBOLS	MIN.	MAX.
A	-	1.75
A1	0.10	0.25
A2	1.25	-
b	0.31	0.51
c	0.10	0.25
D	4.90 BSC	
E	6.00 BSC	
E1	3.90 BSC	
e	1.27 BSC	
L	0.40	1.27
h	0.25	0.50
θ°	0	8

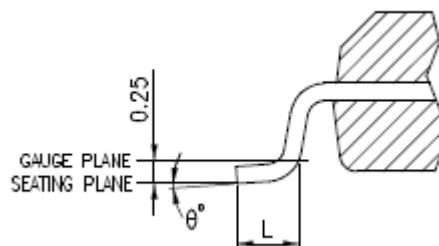

UNIT : mm

6. Electrical Characteristics

6.1. Absolute Maximum Ratings (Ta=25°C, unless otherwise noted)

Parameter	Symbol	Ratings	Unit	Conditions
S/OCP Pin Voltage	V _{OCP}	-2~6	V	
Power Supply Voltage	V _{CC}	32	V	
AS Pin Voltage	V _{AS}	-0.3~6	V	
LS Pin Voltage	V _{LS}	-0.3~6	V	
COMP Pin Voltage	V _{COMP}	-0.3~6	V	
Power Dissipation	P _{D1}	1.0	W	※1
Operation Temperature	T _{opr}	-20~+125	W	
Storage Temperature	T _{stg}	-40~+125	°C	
Channel Temperature	T _{ch}	+150	°C	

Notes ※1 Mounted on board size TBD, SOP8 package

6.2. Electrical Characteristics of Control (V_{CC}=18V, Ta=25°C, unless otherwise noted)

Parameter	Symbol	Values			Unit	Conditions
		MIN	TYP	MAX		
Power Source / Start-up Functions						
Start Supply Voltage	V _{CC(ON)}	11.5	13	14.5	V	
Stop Supply Voltage (Under Voltage Lock Out)	V _{CC(OFF)}	6.5	7.5	8.5	V	
Operating Circuit Current	I _{CC(ON)}	—	—	3	mA	
Minimum Start Voltage	V _{ST(ON)}	20	30	42	V	
Start-up Supply Current	I _{startup}	-3.7	-2.5	-1.0	mA	
Supply Threshold Voltage	V _{CC(BIAS)}	9	10	11	V	
Oscillator Functions						
Average Oscillator Frequency	f _{osc(ave)}	60	67	74	kHz	
Oscillator Frequency modulation	Δf	1	5	9	kHz	
Maximum On Duty	D _{max}	75	83	92	%	
Minimum On Time	T _{ON(MIN)}	—	420	—	ns	
Over Current Protection Functions						
Leading Edge Blanking Time	T _{LEB}	—	280	—	ns	

Drain Peak Current Adjustment Value	DPC	—	20	—	mV/μs	
Drain Peak Current Adjustment Limit Duty	DDPC	—	36	—	%	
OCP Threshold Voltage (at Zero On Duty)	VOCP(L)	0.70	0.78	0.86	V	
OCP Threshold Voltage (at 36% Duty)	VOCP(H)	0.81	0.9	0.99	V	
Reference Source / Error Amp Functions						
Reference Voltage	VL(REF)	270	300	330	mV	
Erramp Gain	gm	33	67	100	μS	
Erramp Source Current	ICOMP(SO)	-30	-20	-10	μA	VL(REF)-0.3V
Erramp Sink Current	ICOMP(SINK)	10	20	30	μA	VL(REF)+0.3V
AS Threshold Voltage	VAS	270	300	330	mV	
Over Voltage Protection / Thermal Shut Down Functions						
OVP Threshold Voltage	VCC(OVP)	22.5	25	27.5	V	
TSD Junction Temperature	Tj(TSD)	135	—	—	°C	

7. Power Supply IC Circuit Connection Example

Example 1: LED bulb model (non-isolated, universal input voltage range, output~9W)

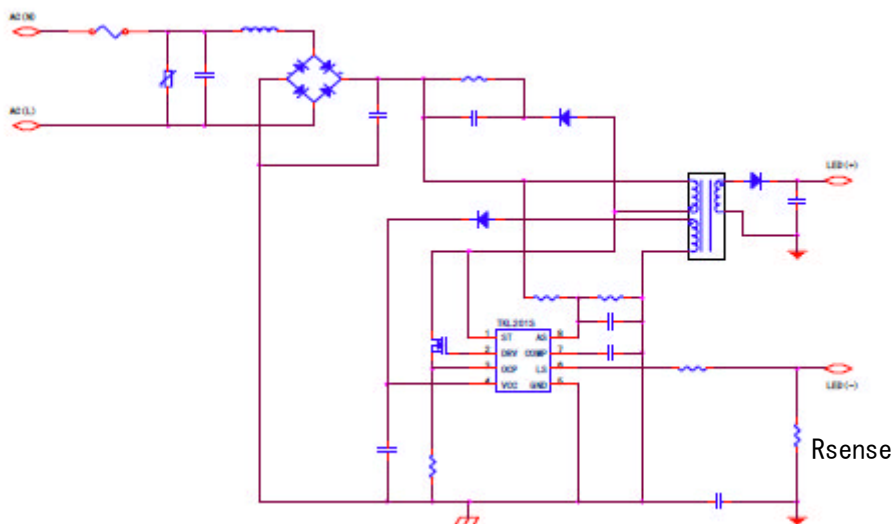

Points on circuit design

1. Rsense is calculated by $0.3 / \text{output current}$. 0.3V is as reference voltage.
2. 50ns as Trr of diodes is recommended.
3. Designers need to determine operating voltage and current on the devices, device-type on the basis of the application specification of input voltage and output voltage, output (load) current.
4. TKL201S is an IC for fly-back converter. Transformer-cores and constants made by TDK etc. are supposed.
5. Size and shape of transformer's core are determined by the input voltage range, minimum startup voltage, oscillator frequency, output voltage, output current.
6. EMI measures
 - Noise filter against common mode and normal mode noise
 - Reduction of switching spike on MOSFET.
 - Reduction of switching spike by diode on secondary side.
 - Reinforcement of circuit ground
 - Put the parts connected to COMP-pin and LS-pin, DRV-pin closer to TKL201S.
 - Reduce the line impedance by reduction of inner-side-area of primary and secondary side patterns. Because closed loop current appear on the inner-side-area.

Recommended MOSFET specifications

Power consumption	100VAC	85-265VAC	Package
~4W	450Vmin / 5Ω max	600Vmin / 5Ω max	DPAK IPAK
~10W	450Vmin / 2Ω max	600Vmin / 2Ω max	DPAK IPAK
~30W ~50W	450Vmin / 1Ω max	600Vmin / 1Ω max	D2PAK TO-220
~70W	450Vmin / 0.5Ω max	600Vmin / 0.5Ω max	TO-220
~100W	450Vmin / 0.1Ω max	600Vmin / 0.1Ω max	TO-3P

Example 1: Power consumption 9W (output 78V/0.1A)

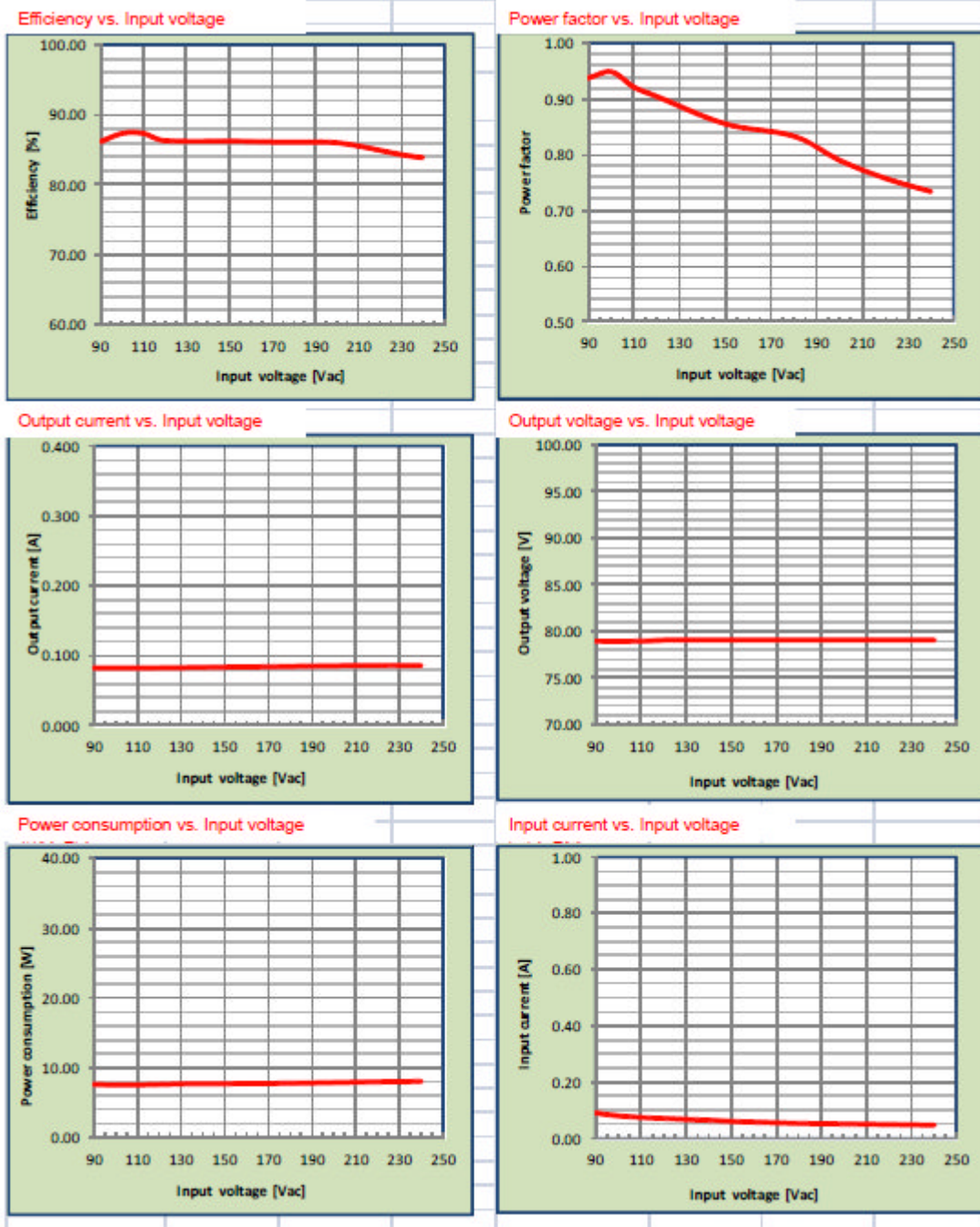

Example 2: Power consumption 29W (output 82V/0.3A)

Efficiency vs. Input voltage

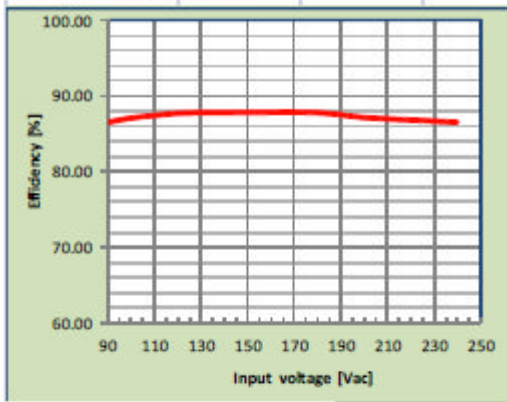

Power factor vs. Input voltage

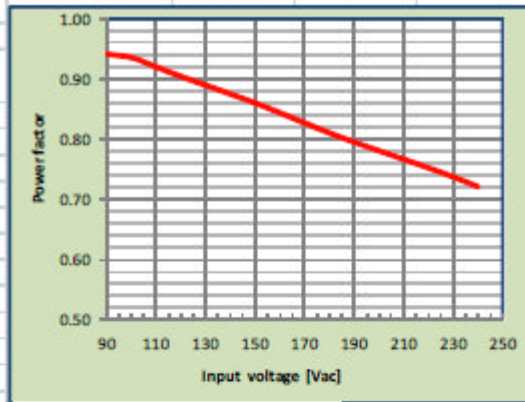

Output current vs. Input voltage

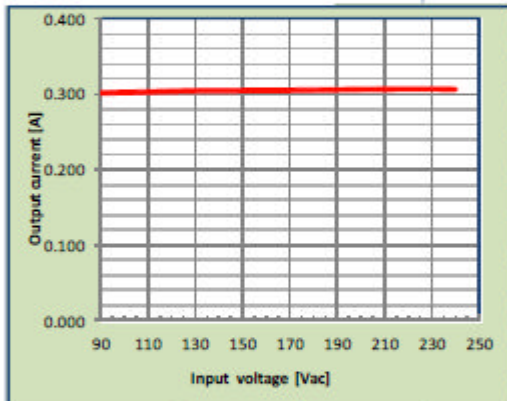

Output voltage vs. Input voltage

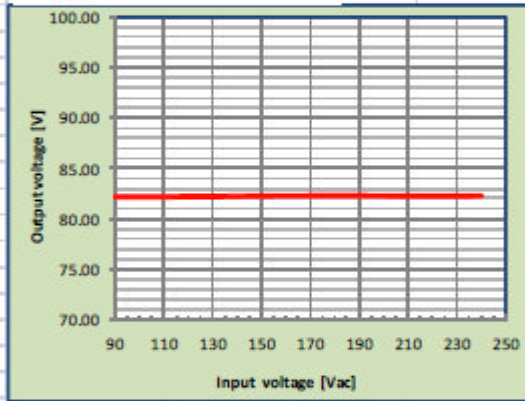

Power consumption vs. Input voltage

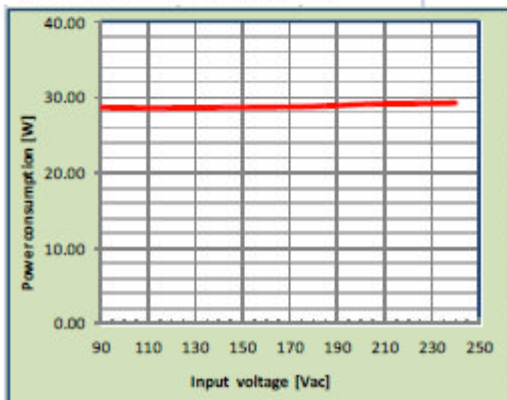

Input current vs. Input voltage

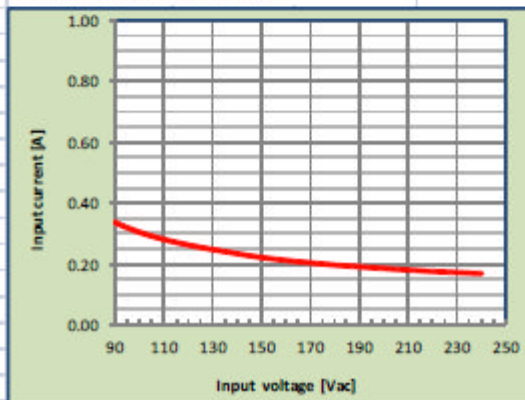

Example 3: Power consumption 70W (output 87V/0.7A)

Efficiency vs. Input voltage

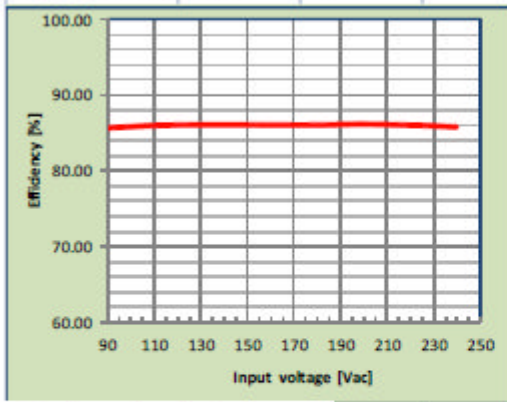

Power factor vs. Input voltage

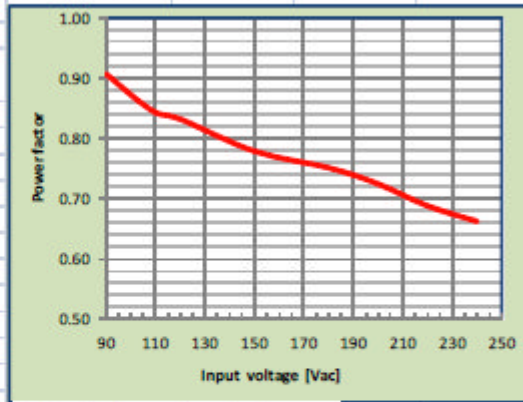

Output current vs. Input voltage

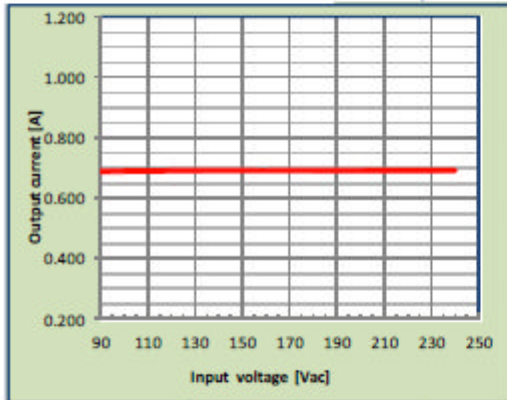

Output voltage vs. Input voltage

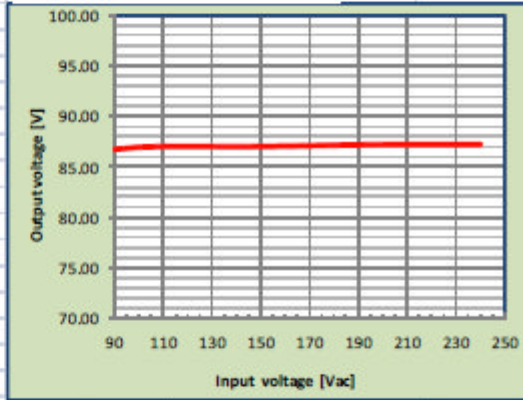

Power consumption vs. Input voltage

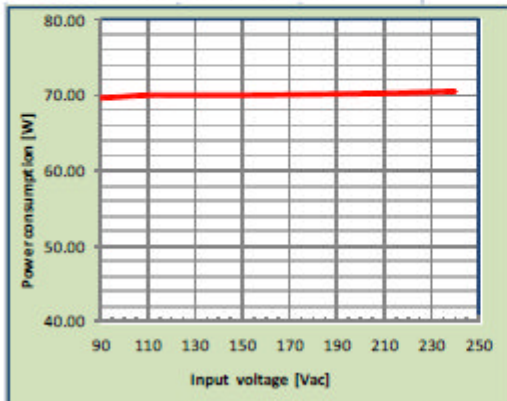

Input current vs. Input voltage

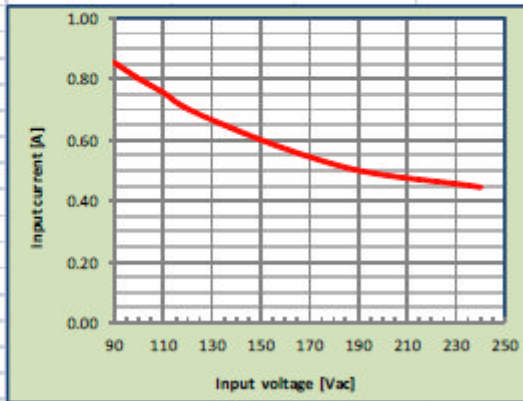

8. Functional Description

8.1. Operating Oscillation

The general power supply IC has large capacitors which is essential to DC power supply structure. There is the input voltage monitor intermittent operation as the LED driver type which does not need large capacitors. The source of supply operating of the IC itself becomes a bridge output. The IC is possible to watches intermittent of this supply voltage and controls transformer and LED output. For the present conditions of the IC, this monitor level is adjustment AS terminal (8pin) and operate repeatedly, and it is considered to lose a visual blink by LED driving pulse.

PWM controls the power MOSFET at average oscillator frequency, and feedback controls that assumed reference voltage a standard to keep a fixed LED output current. The inside reference voltage to use for this current control regards it as low voltage 0.3VTyp to reduce a loss of current sense resistance.

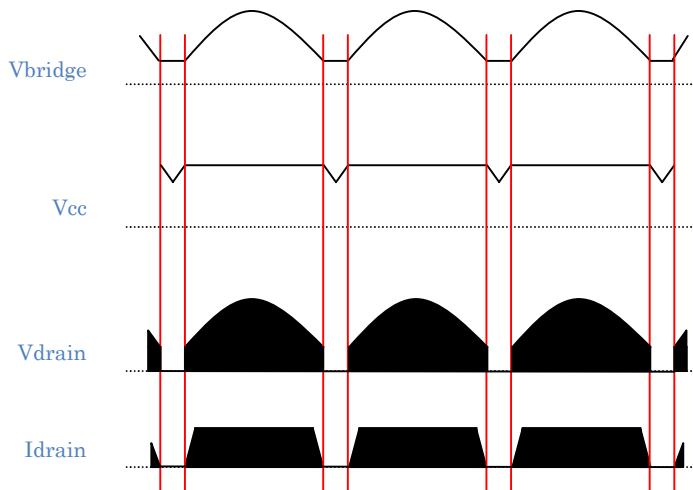

Figure1 Standard Sequence

In addition, the typical oscillator frequency $f_{osc(ave)}$ is set to an average of 67kHz, and it is equipped with a random switching function for noise reduction of the same frequency.

< Random Switching Function >

The IC is equipped with a random switching function in PWM control. According to the statement above, it can simplify to noise filters of input so that noise reduction of the same frequency. During switching operation, it lets slightly change in typically 5kHz peak-to-peak for average frequency at random.

Generally, the inside comparator replies to a sudden surge to occur when the power MOSFET turned on with current control mode. Therefore, there is the case that the power MOSFET turn off. The IC is equipped with a leading edge blanking function to prevent this phenomenon.

<Leading Edge Blanking Function>

This function arranges the blanking time of 280nSTyp from the moment when the power MOSFET turned on, and evades an above phenomenon.

8.2. Power supply and Start-up Circuit

VCC(4pin) is a terminal for the energy supply that is necessary for the control circuit. The start-up circuit is connected to ST(1pin) in the IC inside. The start-up current charges condenser connected to VCC pin. When VCC pin rises to operating supply voltage VCC(ON)=13VTyp, the IC operates. The start-up time is decided to capacity connected Vcc pin, can demand it by next type.

$$T_{START} = C \times (V_{CC(ON)} - V_{CC(int)}) / I_{STARTUP}$$

※TSTART : Start-up time [S], VCC(int) : VCC initial voltage [V], C : Capacity connected Vcc pin[F]

The start-up circuit after starting-up disappear loss by itself to intercept automatically.

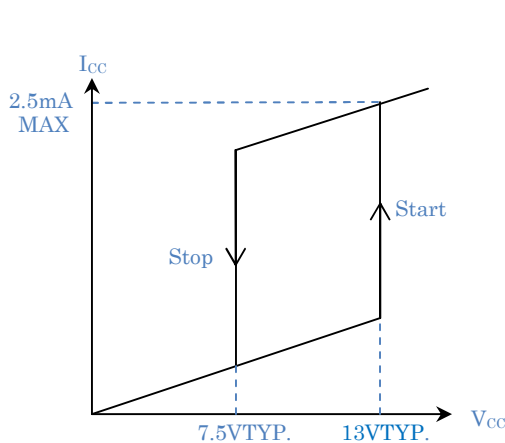

Figure2 Relation of Vcc and Icc

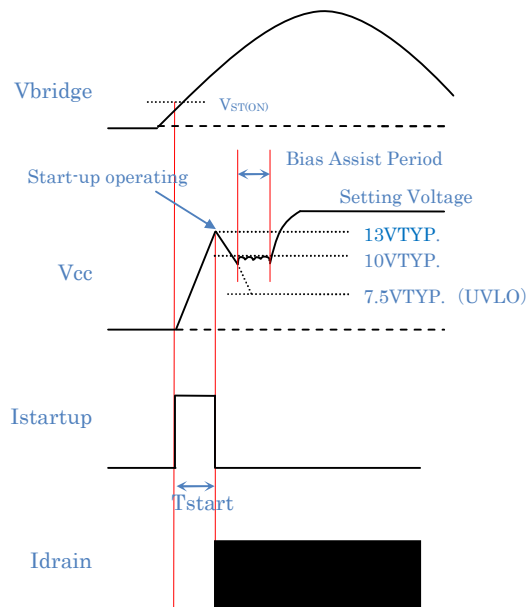

Figure3 Start-up Sequence

Shown in figure 2 is relation of Vcc voltage and circuit current. When the Vcc voltage reaches to 13V typical and the control circuit starts operating, the circuit current

increases. When the Vcc voltage reaches to 7.5V typical, the control circuit stops by under voltage lockout and comes back to the state before start-up again.

After the control circuit operating, the Vcc voltage gets a power supply by doing rectification flatness of winding voltage of a winding D. Please adjust of a winding D at around 20V from 15V. Shown in figure 3 is start-up sequence. The voltage of a winding D does not rise to the setting voltage after the control circuit start operating immediately. Because the Vcc voltage begins to descend and a bias assist function works when the Vcc voltage becomes less than 9.5V typical. During a bias assist function operation, it controls to drop of the Vcc terminal voltage, because the start-up current is supplied from the start-up circuit again.

Shown it in figure 4, there is the case that the Vcc voltage changes by a value of output current in the real power supply circuit. Because it is charged peak capacity connected Vcc pin by a surge voltage to occur when the MOSFET turned off. It is effective to add a resistance in series with a zener diode to prevent this phenomenon. It is really necessary for the most suitable value of this resistance to adjust a transformer to use in different by transformer structure to use.

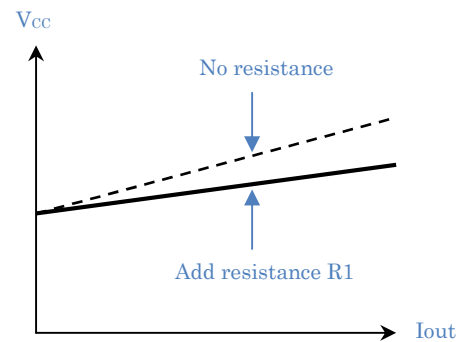

Figure4 Relation of Iout and Vcc

In addition, the rate of change of the Vcc voltage for output voltage turns worse so that transformer combination is bad. Therefore, this peak charge is relaxed by reducing under the influence of the surge voltage from primary winding P to a winding D. From the point of view, it is necessary to attention the scroll position of winding D in the transformer design.

Shown in figure5, figure6 is the reference example of the scroll position of a winding D.

- Separate distance with winding D and primary winding P (figure5)
- Structure to sandwich winding D in second side control winding S (figure6)

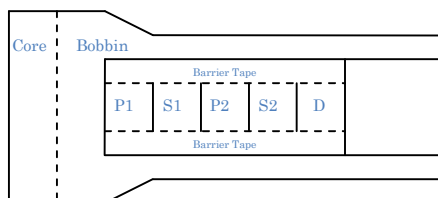

Figure5 Winding structure example1

P1,P2 : primry
S1 : second control
D : for Vcc
S2 : second output

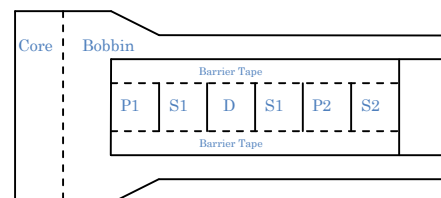

Figure6 Winding structure example2

8.3. Constant Current Control Circuit

The IC converts this current into a voltage for current sense resistance to control output current of the LED and input it into LS(6pin) terminal. The IC controls so that makes constant voltage to this voltage.

Shown in figure 7 is constant feedback waveform. This control voltage is input into the Feedback Control circuit and generates the target voltage of the comparator by adding slope adjustment more. In addition, the Feedback Control circuit operates so that the drain peak current approach to above-mentioned target voltage. As a result, the IC compares this peak value and controls it.

Shown it in figure 8, as for the power supply of the peak current control method, drain current waveform change by a period of integer double of the switching frequency. Such a phenomenon call a sub-harmonic oscillation. It is theoretically problem to occur. Therefore a suitable adjustment that is stable operating is necessary.

In the case of continuous mode, even if the drain peak current is constant, the ON period change for the initial value of drain current. As a result, the suitable operation is not maintained in a period of switching. The IC has the slope compensation circuit built-in to control this phenomenon.

The slope compensation circuit operates so that fall drain peak current as ON duty become wide, and controls a sub-harmonic oscillation.

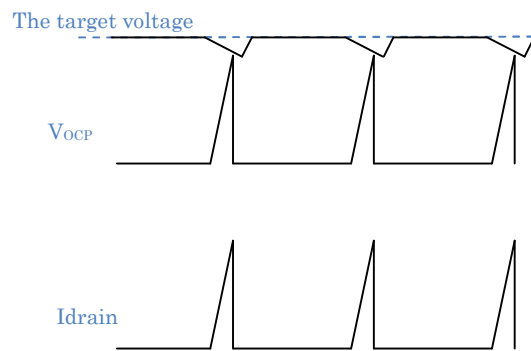

Figure7 Constant Feedback Waveform

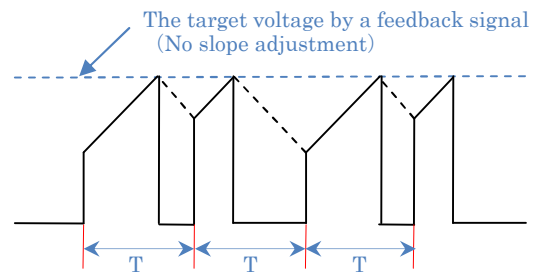

Figure8 Drain Current Waveform by a Subharmonic Oscillation

8.4. Adjustable Over Current Protection Circuit

This circuit detects the peak value of drain current by every pulse and it is switched off the power MOSFET when OCP(3pin) terminal voltage became over the OCP voltage. As this circuit has a input adjustable circuit built-in, it is realized over current protection with a little AC input dependent.

The detection of drain current connects a current sense resistor between OCP(3pin) terminal to GND(5pin) terminal and carries it out. When

the drop voltage by sense resistor reached the OCP threshold voltage, it is turned off the power MOSFET. The general PWM control IC tends to occur unevenness of drain peak current movement point for AC input voltage change.

Shown in figure 9 is output overload characteristics when the overcurrent protection circuit operated.

The IC has a input adjustable circuit built-in to adjust the unevenness. This circuit adjusts a difference of drain peak current movement point for AC input voltage.

This quantity of adjustment depend the value of drain peak current adjustment and on time. OCP threshold voltage after adjustment can demand it by next type.

$$V_{OCP} [V] = V_{OCP(L)} [V] + (DPC [V/\mu S] \times ON Time [\mu S])$$

But, OCP threshold voltage over ON duty 36% become $V_{OCP(H)} = 0.9V_{Typ}$.

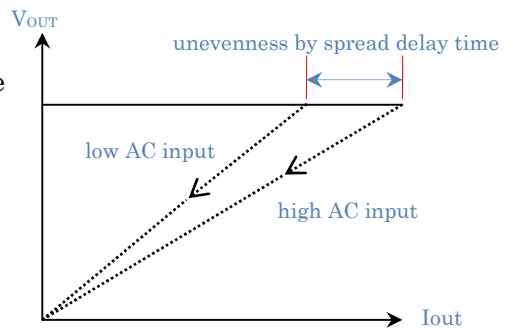

Figure9 output overload characteristics

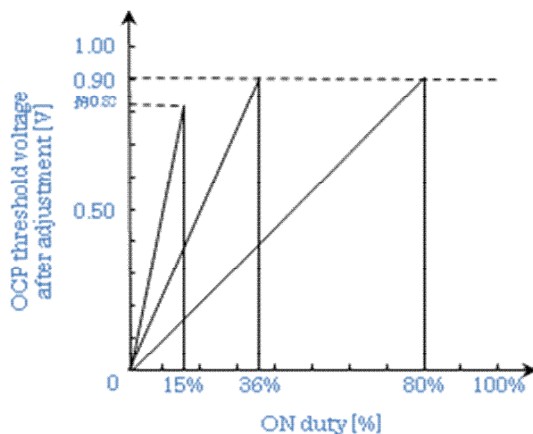

Figure10 Relation of ON duty and OCP threshold voltage after adjustment @ fosc(ave)=67kHzTyp

Shown in figure 10 is relation ON duty and OCP threshold voltage after adjustment. When you designed the transformer to become ON duty 36% in peak load and AC85V, the OCP movement point become to $V_{OCP(H)} = 0.9V_{Typ}$.

8.5. COMP Pin Function

The COMP pin is a terminal for phase compensation of the feedback control circuit. The condenser capacity to add, big one is stable, but it is necessary to adjust a fixed number after having confirmed a lead and delay of phase.

- (1) Stable operation, Abnormal oscillations or not
- (2) Start-up failure and Re-start failure or not

8.6. Latch Function

The latch circuit is stopped switching when OVP circuit and TSD circuit operated each and it protects the IC by keeping the stop state.

This circuit makes the delay time to prevent an irregular operation by noises and operates in the case of following to protect more than a constant time.

When the IC stops switching by this circuit, Vcc terminal voltage begins falling down. When Vcc terminal voltage fallen down to 10V typical, it supplies start-up current in Vcc terminal, and it increase voltage to 13V typical.

The latch cancellation turns off AC input once basically and it is canceled by falling Vcc terminal voltage to less than 7.5V typical.

8.7. Thermal Shut Down Circuit

When the junction temperature of IC reaches to 135°C by rising of the ambient temperature, the latch circuit operates.

The real temperature detection goes in a control element.

8.8. AS Pin Function

AS Pin is a terminal to monitor input voltage and, set the interregnum of oscillation movement, in other words that have the function that can set the minimum operating voltage. It is possible to set R2 in figure 11. AS threshold voltage $V_{AS}=0.3V \pm 10\%$

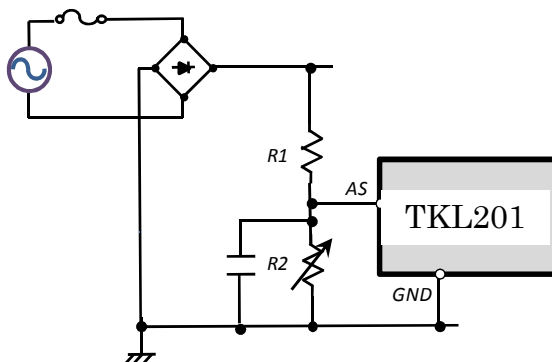

Figure11 AS pin connection example

8.9. Over Voltage Protection Circuit

When the power supply IC became the no load state in constant current control, it become uncontrollable and occur to overvoltage in output. With it, the Vcc terminal voltage rises too. Shown in figure 12 is OVP circuit sequence.

The IC have the over voltage protection function built-in to protect output and load from overvoltage. The IC does not directly monitor, but it protects load by monitoring Vcc terminal voltage. In other words, the latch circuit operates and stops switching when Vcc terminal voltage exceeds 29V typical.

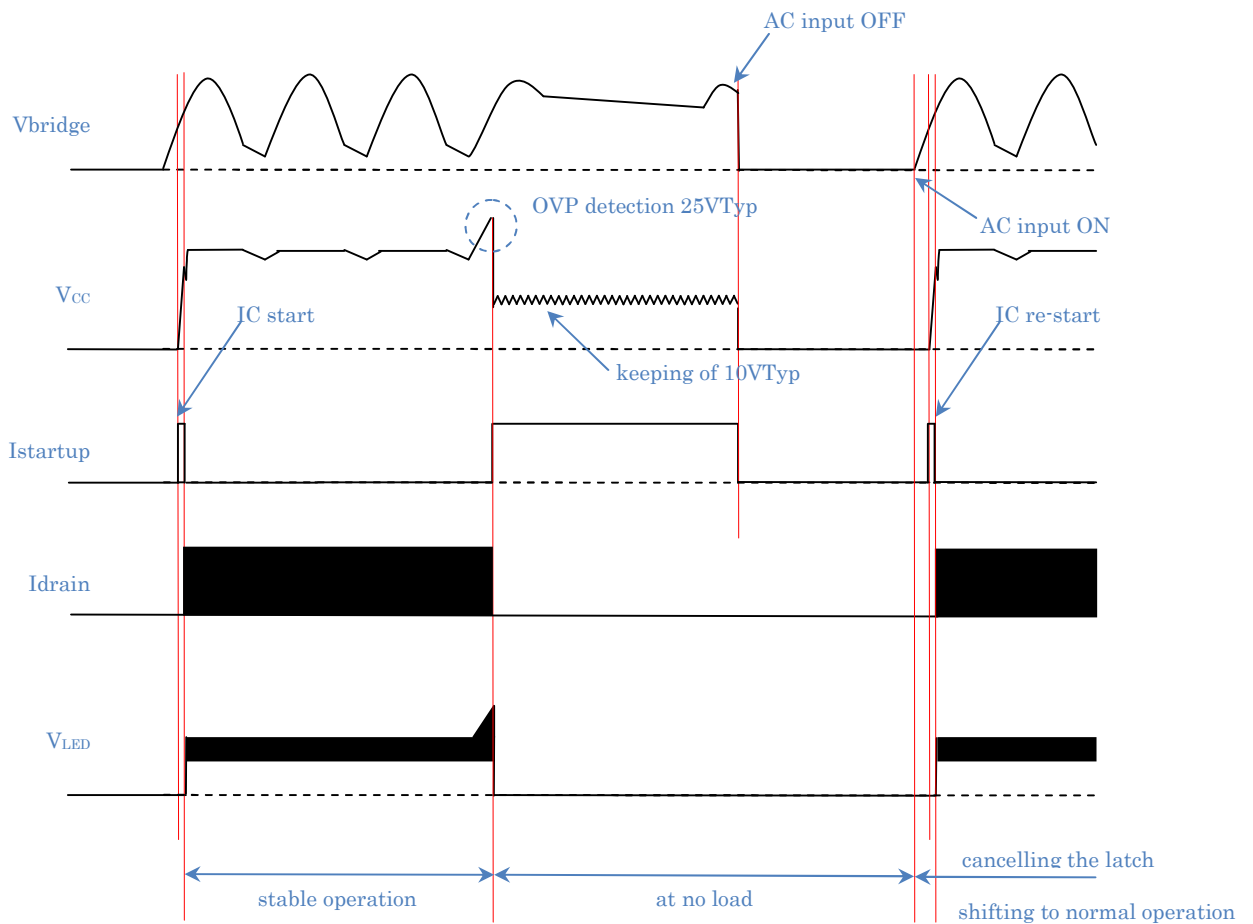

Figure12 OVP Circuit Sequence

NOTICE

- The contents in this document are subject to modify, for improvement and other purposes without notice. Please make sure that the document is the latest version before use.
- The operation and circuit example in this document are provided for reference purposes only.

We take on no responsibility for violation of industrial property, intellectual property, other rights of us or the third parties that be attributed to these examples.

- In the case of using that the product in this document, the user must take on responsibility for considering and determining.
- We will continue to improve quality and reliability of our products, but semiconductor products have certain fault and failure rates by nature.

The user must take on responsibility for designing and checking to secure equipment and system so that a part failure may not lead to injury accident, fire, social damages and others.

- Please don't use these products for devices that request high responsibility (such as transport machines and their control units, disaster prevention equipments, any kind of security equipments, aerospace instruments, nuclear power control units, medical instruments for life support and others.)